

# ANALOG PHASE SHIFTER

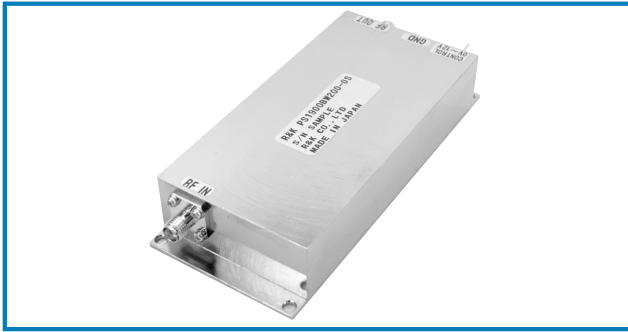

## R&K-PS1900BW200-0S



### OUTLINE DRAWING

※ IN MILLIMETERS

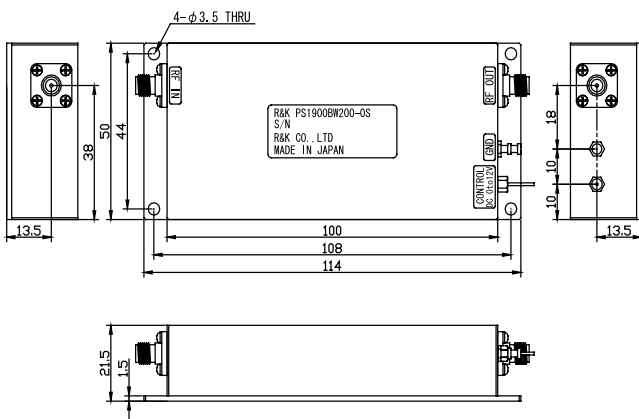

- Frequency Range : 1800MHz~2000MHz
- Insertion Loss : 6dB (max.)
- Phase Control Voltage : 0 ~ +12V
- Phase Shift Range : 0 ~ 360°
- RoHS Compliance

### SPECIFICATIONS

Frequency Range	: 1800 - 2000MHz
Phase Shift Range	: 0 ~ 360° (min.)
Phase Stability	: 2° (Peak max)Fix Temp.
Phase Control Voltage	: 0 ~ +12V / 1kΩ
	: DC - 100kHz (min.)
Phase Control Linearity	: 15% (typ.)
Insertion Loss	: 6dB (max.)
Maximum RF Input Power	: +15dBm (max.)
Impedance	: 50Ω
In / Out VSWR	: 2.5:1 (typ.)
Input I.C.P.	: +17dBm (typ.)
Operating Temperature	: -20°C to +60°C
Storage Temperature	: -20°C to +80°C
Connectors (Standard)	: SMA-FEMALE
Connectors (Option)	: N-FEMALE
Weight (SMA Connector)	: 190g (typ.)

### HOW TO ORDER

Model Name  
R&K-PS1900BW200-0S S = SMA - FEMALE  
N = N - FEMALE

### TYPICAL PERFORMANCE Temp @+25°C

#### Phase Characteristic

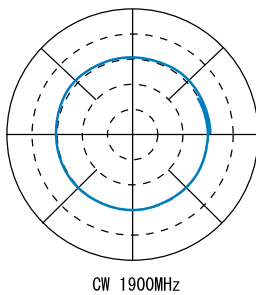

#### Input / Output VSWR

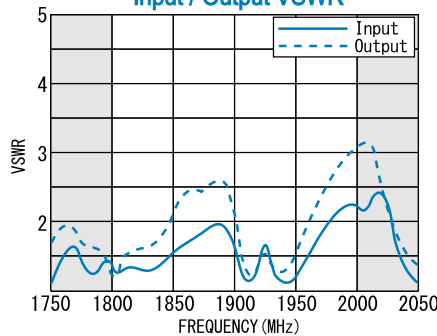

#### SCHEMATIC

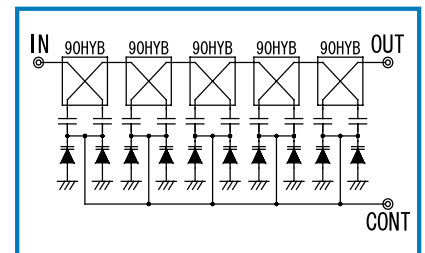

#### Control vs Loss & Phase CW 1800MHz @Pin=0dBm

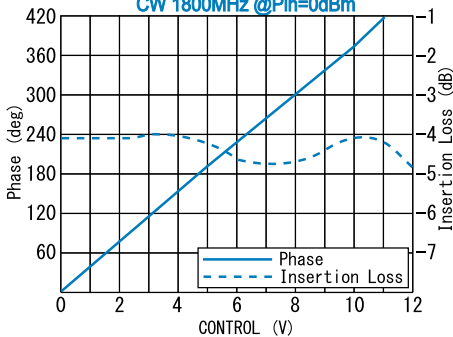

#### Control vs Loss & Phase CW 1900MHz @Pin=0dBm

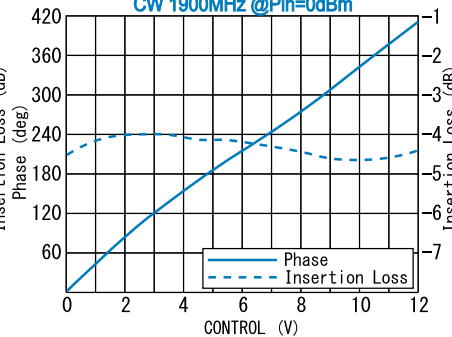

#### Control vs Loss & Phase CW 2000MHz @Pin=0dBm

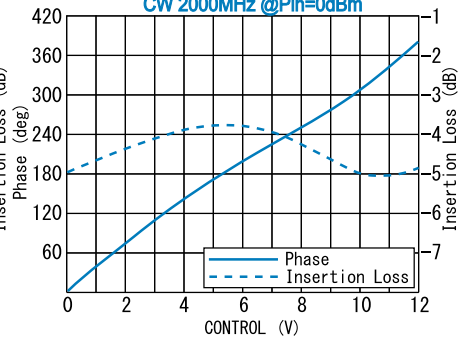

R&K reserves the right to make changes in the specifications of or discontinue products at any time without notice. R&K products shall not be used for or in connection with equipment that requires an extremely high level of reliability and safety such as aerospace uses or medical life support equipment. Further, R&K cannot export products to any country for use in military or defense applications.

## R&K Company Limited

721-1 Maeda, Fuji-City, Shizuoka-Pref. 416-8577 Japan  
Tel: +81-545-31-2600 E-mail: info@rkco.jp  
Fax: +81-545-31-1600 URL: http://rk-microwave.com